

**ORDINANCE NO. 2022 - 73**

**AN ORDINANCE REVISING THE SITE WIDTH MEASUREMENT DIAGRAMS FOR RESIDENTIAL SITES, THEREBY AMENDING CHAPTER 21 OF THE CITY CODE.**

The City Council of the City of Bloomington, Minnesota ordains:

Section 1. That Chapter 21 of the City Code is hereby amended by deleting those words that are contained in brackets and ~~stricken through~~ and adding those words that are underlined, to read as follows:

\*\*\*

**CHAPTER 21: ZONING AND LAND DEVELOPMENT**

\*\*\*

**ARTICLE III: DEVELOPMENT STANDARDS**

**DIVISION A: GENERAL STANDARDS**

**§ 21.301.01 DEVELOPMENT INTENSITY AND SITE CHARACTERISTICS.**

\*\*\*

(c) *Residential Zoning Districts.*

(1) *Residential site standards.*

\*\*\*

(A) *Site width.* Site width for non-corner sites must be at least 80 feet in the R-1 and RS-1 zoning districts and at least 100 feet in the R-1A zoning district. Corner site width at both of the minimum required front setback lines must be at least 120 feet in the R-1, RS-1 and R-1A zoning districts. Single and two-family residential sites approved by the city after August 31, 2006 must meet minimum site width requirements at the front setback line and over the first 50 feet of the site beyond the required front setback line.

(i) *Graphic illustration.* Site width measurements.

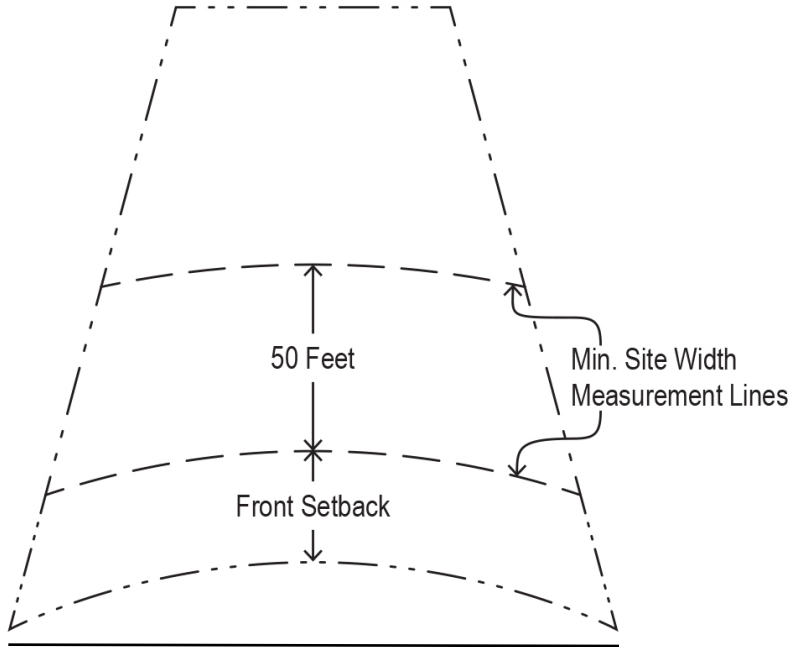
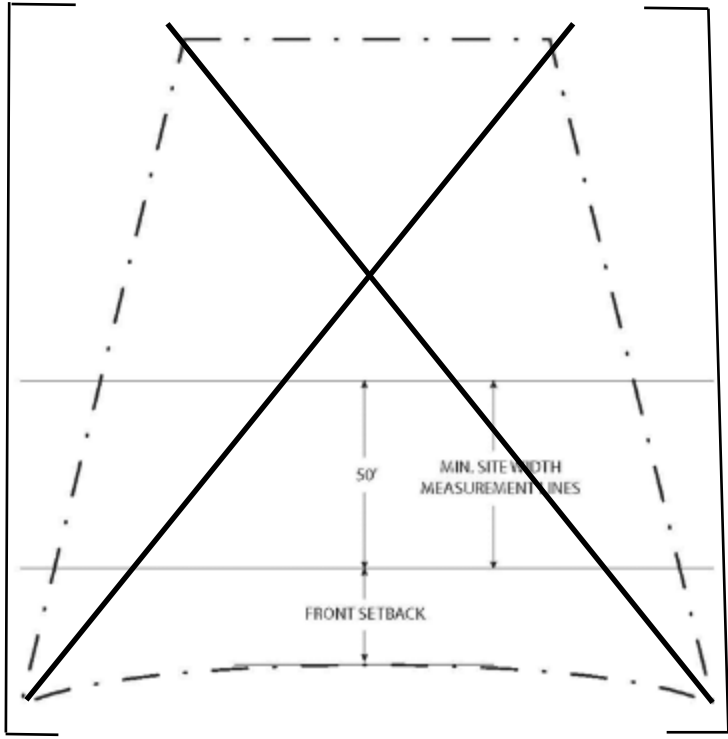

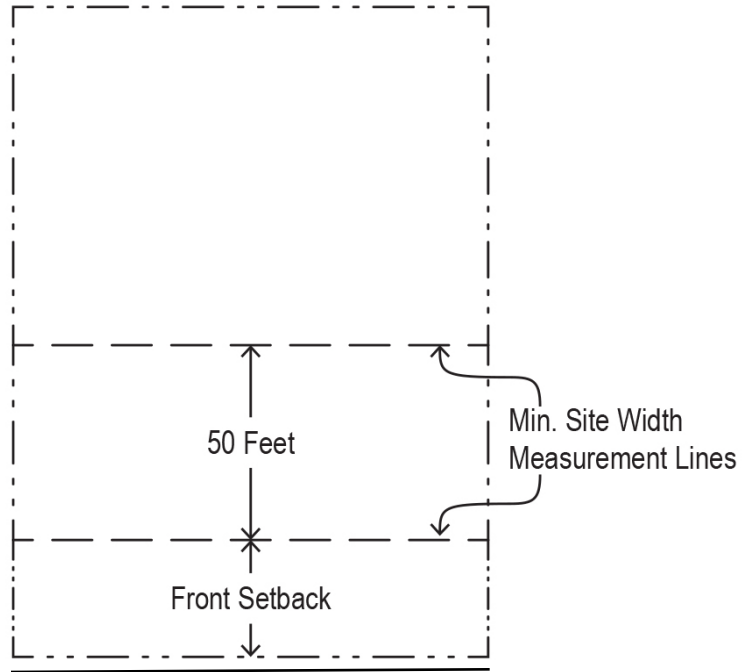

Passed and adopted this 19th day of December, 2022.

/s/ Tim Busse  
Mayor

ATTEST:

/s/ Matt Brillhart  
Secretary to the Council

APPROVED:

/s/ Melissa J. Manderschied  
City Attorney